



**SUBARU**

PART NUMBER: E361SSC200

**INSTALLATION  
INSTRUCTIONS**

**DESCRIPTION:  
FORESTER / IMPREZA / XV CROSSTREK CROSSBAR KIT**

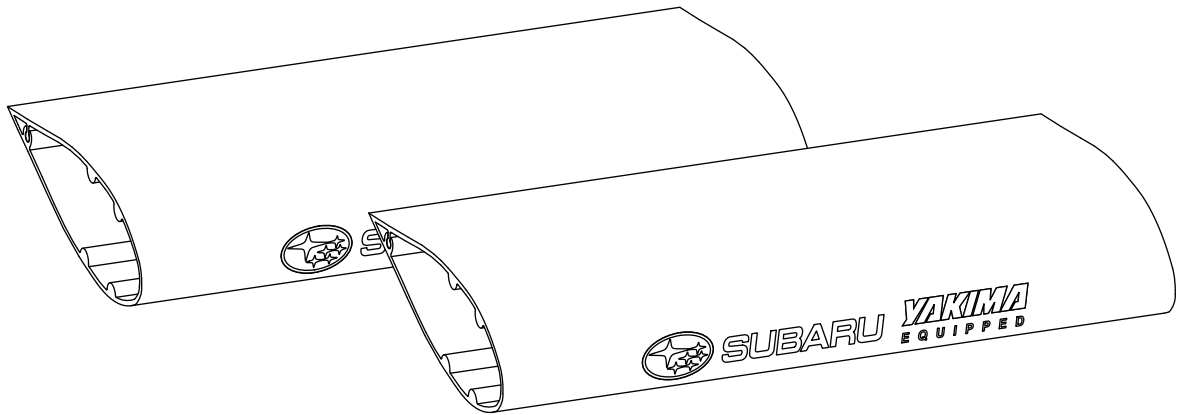
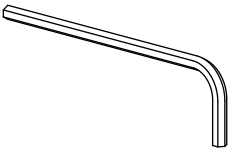
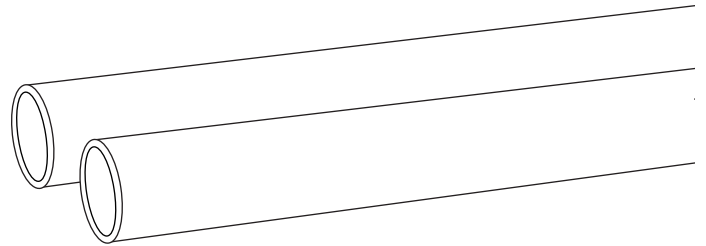
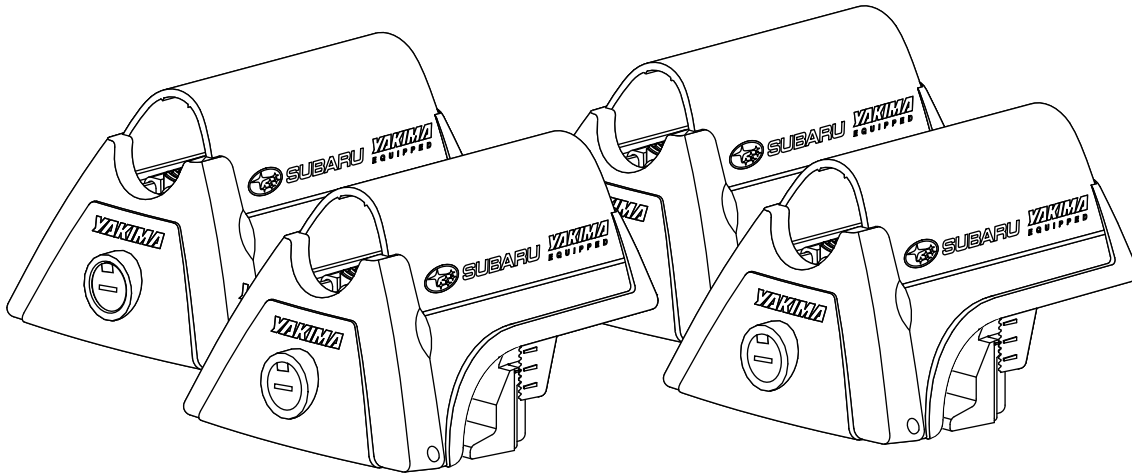

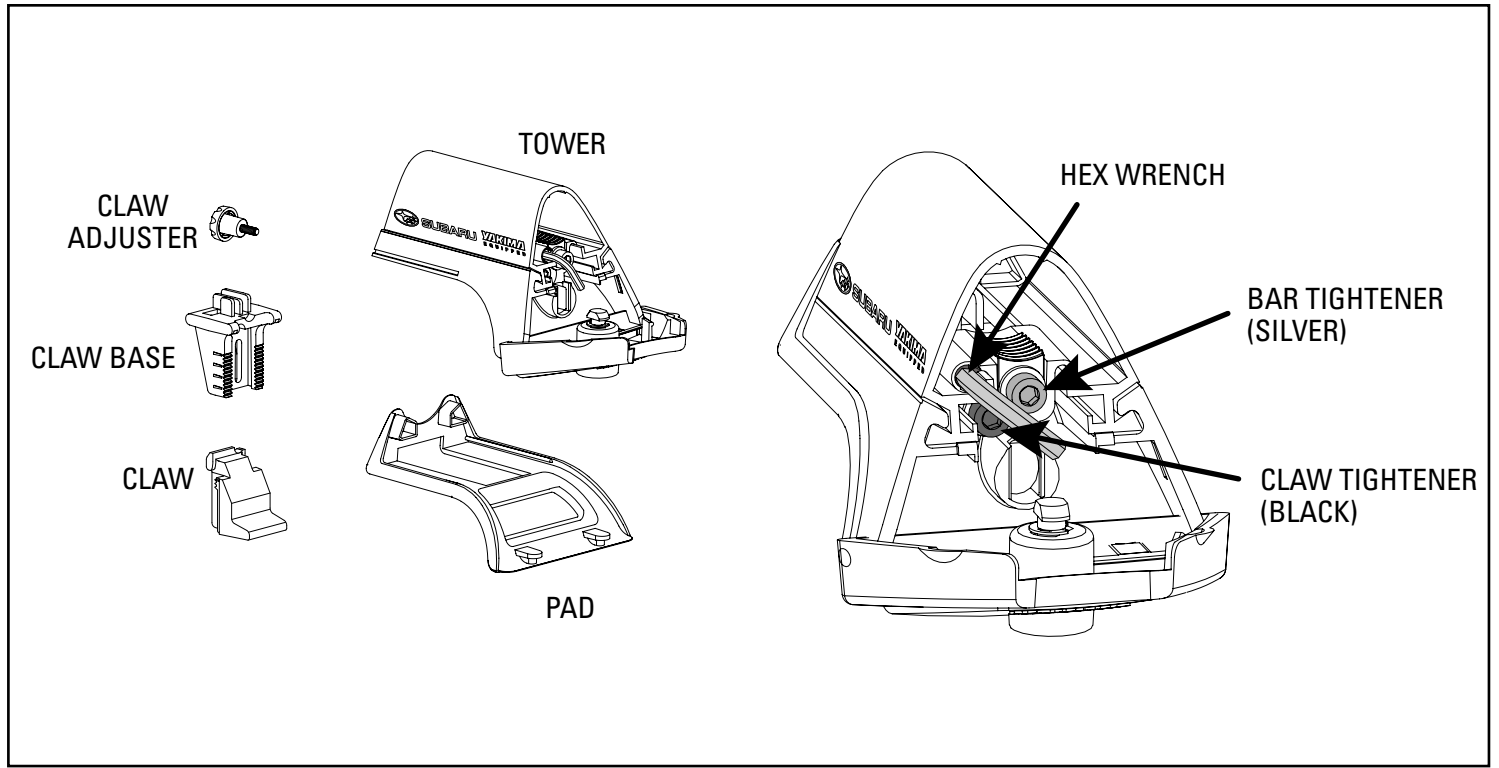
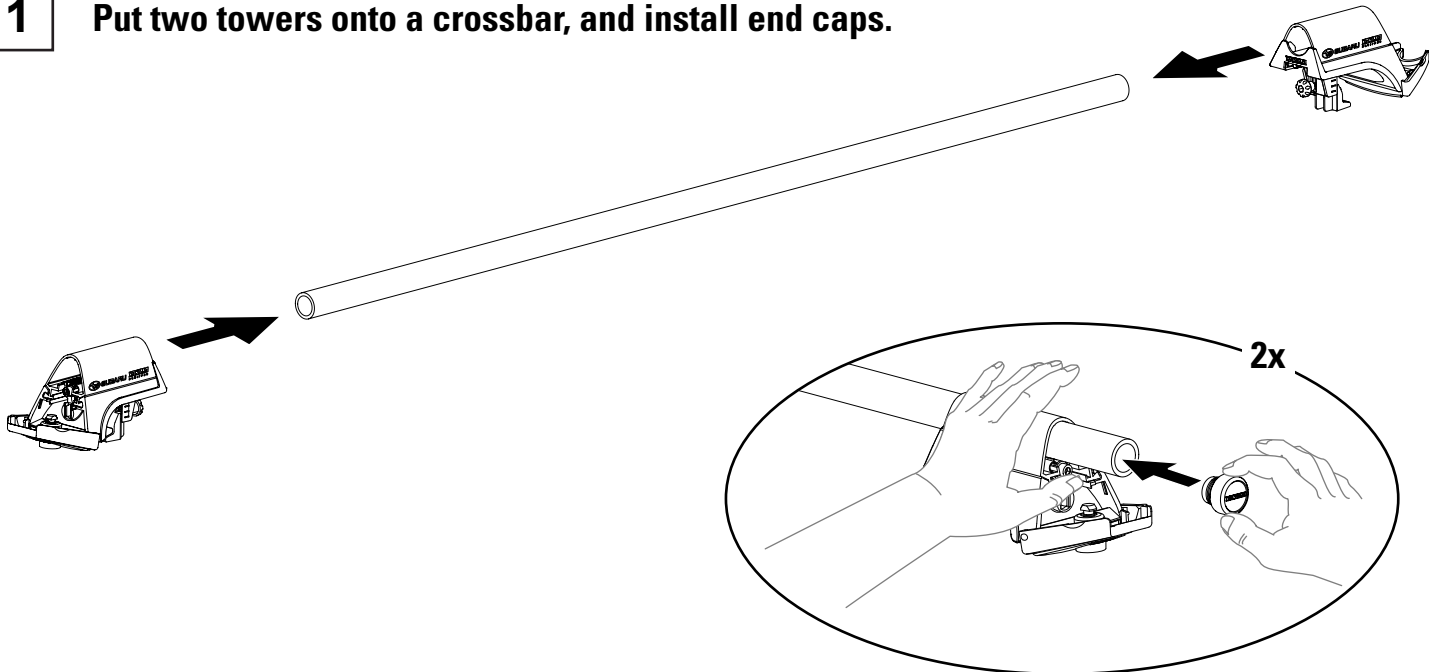
**INSTALLATION  
INSTRUCTIONS****DESCRIPTION:  
FORESTER / IMPREZA / XV CROSSTREK CROSSBAR KIT****1 Put two towers onto a crossbar, and install end caps.**

**NOTE:** If necessary, loosen the silver bar tightener a couple turns using the integrated assembly device.



**SUBARU**

PART NUMBER: E361SSC200

**INSTALLATION  
INSTRUCTIONS**

**DESCRIPTION:  
FORESTER / IMPREZA / XV CROSSTREK CROSSBAR KIT**

**2 Adjust the claw vertically.**



Loosen knob.

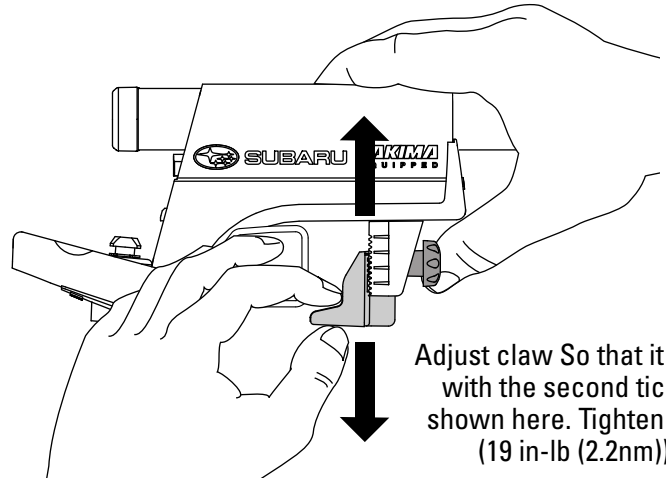

Adjust claw so that it aligns with the second tick as shown here. Tighten knob (19 in-lb (2.2nm)).

**3 Put towers and bar onto rack.**

Position front towers an equal distance from front of car.

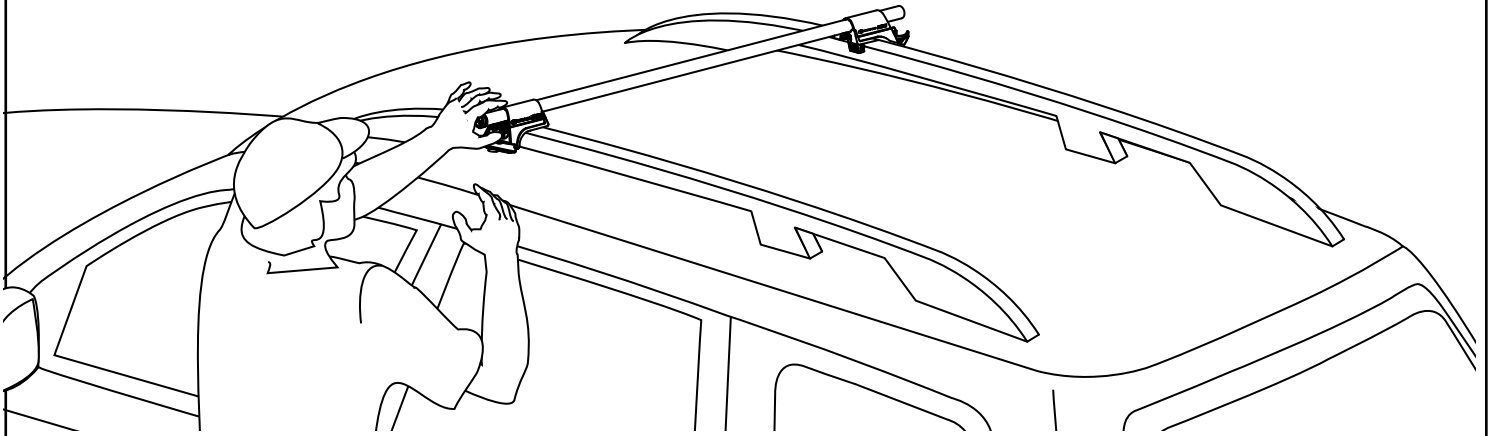

**4 Adjust the claw horizontally.**

Complete claw adjustment by turning the black claw tightener clockwise using the included wrench.

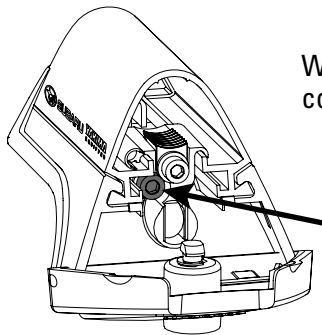

With the covers open...

Locate the black claw tightener.

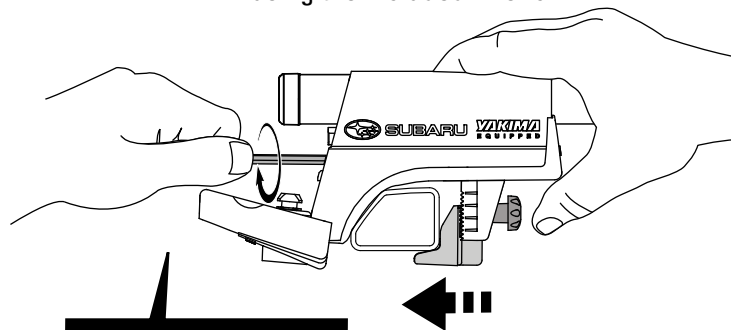

**88 in-lb (10 Nm)**

**5 Check your work.**

Did you establish three *solid* contact points?

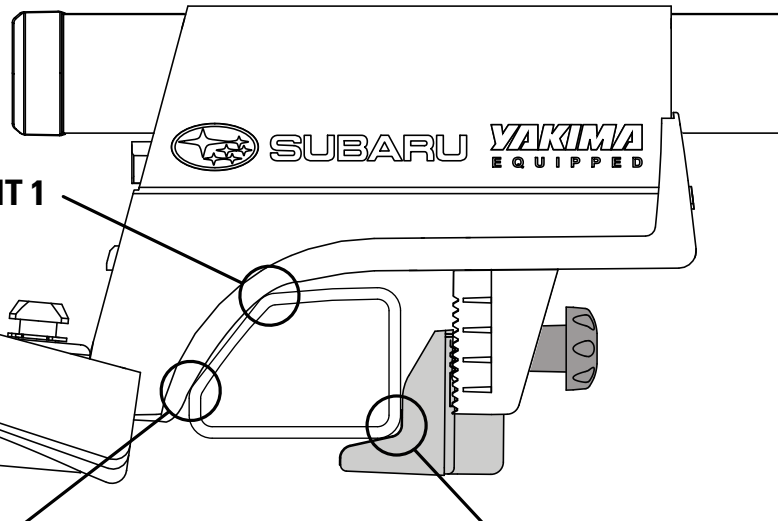
**CONTACT POINT 1**
**CONTACT POINT 2**
**CONTACT POINT 3**

**6 Center round bar.**

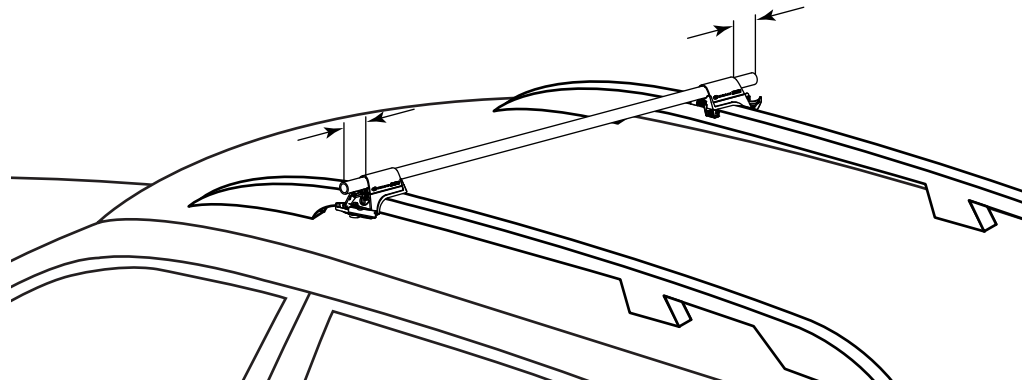
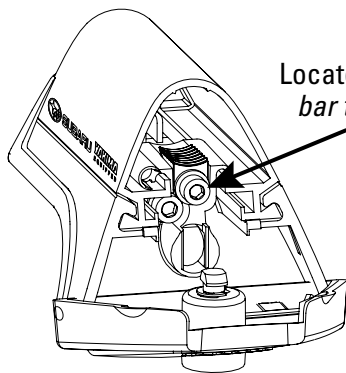
Center the bar so that the ends of the crossbar protruding from the towers are set to an equal distance.



**7 Complete assembly of tower/bar system.**

Locate the silver *bar tightener*.

Assemble bar to tower by tightening silver bar screw using integrated assembly device.

Verify that towers are secure. If movement occurs, retighten towers.

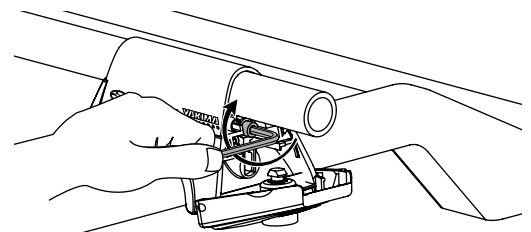
**Be sure to tighten both towers!**



**88 in-lb (10 Nm)**



## INSTALLATION INSTRUCTIONS

## DESCRIPTION: FORESTER / IMPREZA / XV CROSSTREK CROSSBAR KIT

### 8 Check your work.

**CHECK THE INSTALLATION!**  
*Grip the crossbar inboard to towers;  
push and pull using only arm strength.*

*The vehicle should rock back and forth,  
but the rack should not budge.*

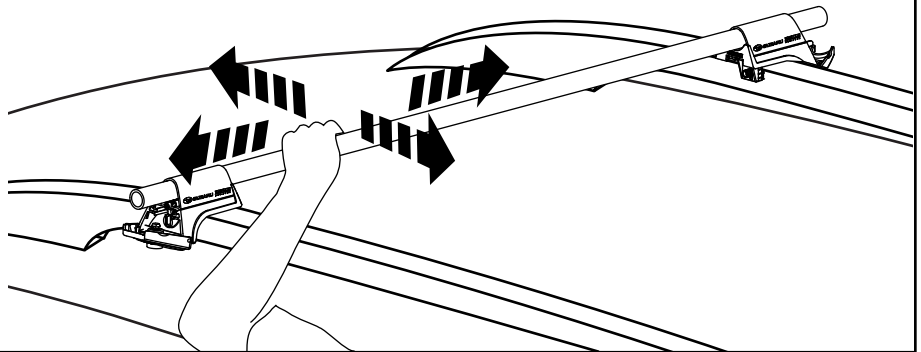

### 9 Install second set of towers and crossbar.

Now simply follow the instructions from the beginning to install your second set of towers. Position rear towers an equal distance from front towers. Be sure to read all cautions and warning on the next page. Return integrated assembly device to storage location. Close the covers. Lock the towers.

### 10 Install air deflector.

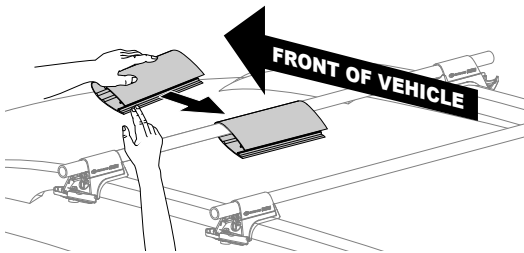

Install air deflector to front  
and rear crossbar.

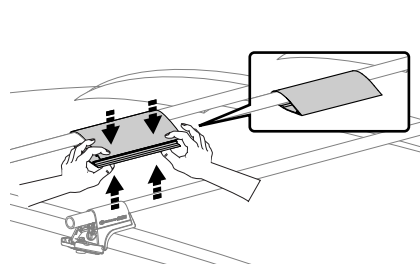

Press edges together to  
close deflectors.

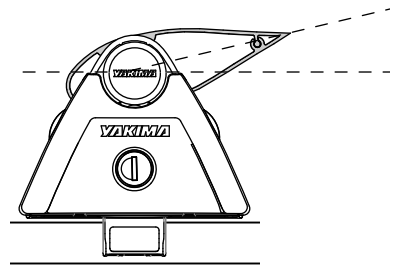

Angle upward slightly.

**NOTICE: THIS CLAMP-ON RACK IS INTENDED FOR USE WITH OTHER GENUINE SUBARU RACK MOUNTED ACCESSORIES, SUCH AS THE BIKE RACK, SKI RACK, KAYAK STACKER, AND ROOF CARGO BASKET. YOU MAY HEAR AN INCREASED LEVEL OF WIND NOISE OR WIND RUSH SOUND AS A RESULT OF INSTALLING THIS RACK ON YOUR VEHICLE. IF THE NOISE LEVEL IS OBJECTIONABLE, THE RACK BARS SHOULD BE MOVED REARWARD ON THE VEHICLE OR REMOVED AND INSTALLED ONLY WHEN UTILIZED TO TRANSPORT SOMETHING.**

### **REMOVING THE RACKS**

1. Mark tower location with marker or tape.
2. Unlock towers and open covers.
3. Loosen claws (claw tightener).
4. Lift rack up and off (do not disassemble).

### **INSTALLING RACKS AGAIN**

1. Open covers.
2. Clean rails and place towers at marked positions.
3. Make sure towers are seated properly, then tighten claws (using claw tightener) close covers and lock.

**PERFORM SAFETY CHECKS ON ALL TOWERS!**



**SUBARU**

PART NUMBER: E361SSC200

**INSTALLATION  
INSTRUCTIONS**

**DESCRIPTION:  
FORESTER / IMPREZA / XV CROSSTREK CROSSBAR KIT**



**WEIGHT LIMITS: MAXIMUM LOAD MUST NOT BE EXCEEDED.**



**THE LOAD LIMIT FOR THIS  
PRODUCT ON YOUR SUBARU  
SHOULD NOT EXCEED THE  
LOAD LIMIT SPECIFIED IN THE  
VEHICLE OWNER'S MANUAL,  
EVENLY DISTRIBUTED.**

### REAR GATE

*Some longer loads may  
prevent the rear gate from  
fully opening.*

**USE CAUTION WHEN  
OPENING YOUR REAR GATE.**

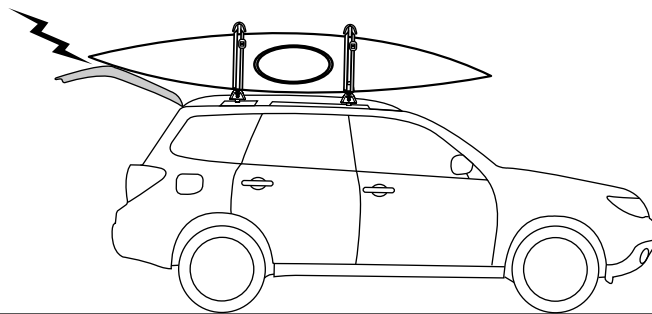

### SUN ROOF

*Sunroof may interfere  
with crossbars or  
accessories.*

**USE CAUTION WHEN  
OPENING SUNROOF.**

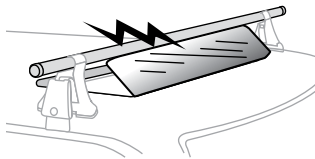

### ANTENNA

Antenna on the roof may need to be removed to  
prevent interference with the rack or long loads.

### TIE DOWN LONG LOADS

Always tie down both ends of long loads  
to vehicle. Failure to do so can result in  
property damage, personal injury, or death.

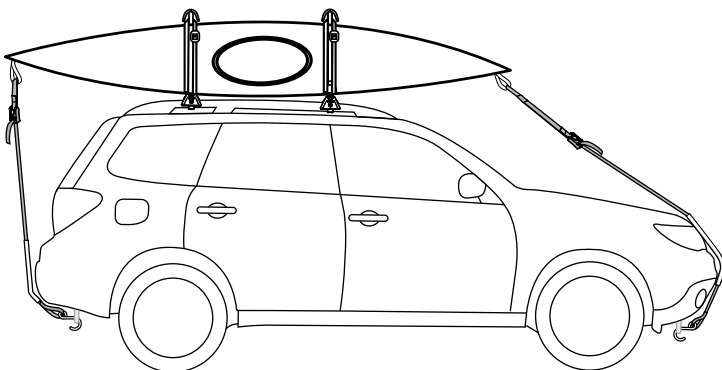

### MAINTENANCE

Use non-water soluble lubricant on screws.  
Use a soft cloth with water and mild  
detergent to clean plastic parts.

**REMOVE RACKS BEFORE ENTERING  
AN AUTOMATIC CAR WASH.**

**WARNING: BE SURE ALL HARDWARE IS SECURED ACCORDING TO INSTRUCTIONS. ATTACHMENT  
HARDWARE CAN LOOSEN OVER TIME. CHECK BEFORE EACH USE, AND TIGHTEN IF NECESSARY.**